

An Introduction to the Lock-In Amplifier and a Mie Scattering Experiment
3 Week Sequence, for Gustavus Adolphus College PHY-305
(Junior advanced lab course)

Contact:

Jessie Petricka
Gustavus Adolphus College
800 W. College Ave.
St Peter, MN 56082
jpetrick@gustavus.edu

Photograph of experiment:

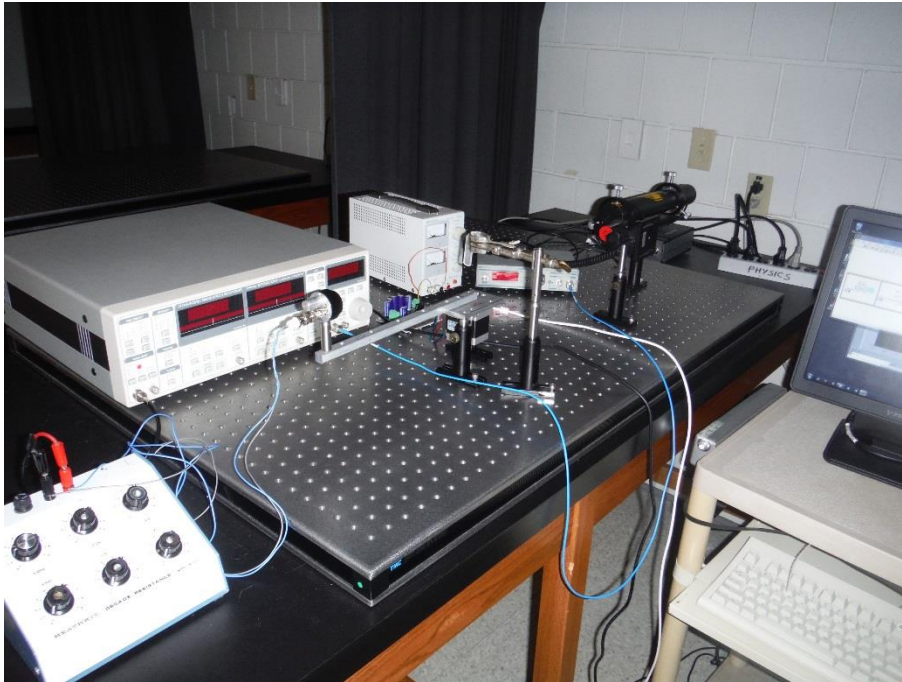

Equipment list:

(generic)

Optical table / breadboard
Various optical components
He-Ne Laser
Lock-in amplifier
Optical chopper
1mm pathlength cuvette
Polystyrene spheres
Stepper motor

(specific if noted)

SRS Inc. Model SR830

2.8 μm dia, Polysciences Inc.
sparkfun.com Model ROB-09238

Stepper motor controller
Stepper mount
Photodiode arm
12V power supply
Photodiode
2 wire cable (light gauge for less strain on photodiode)
Various BNC cables
GPIB cable
Termination resistor / decade box
Computer with LabView, GPIB, MieCalc
Analysis software
Portable audio CD player with connecting wires
Audio CD with pre-programmed signal tracks
Oscilloscope
Function Generator
Optical power meter
Vernier power amplifier
Pyrex beaker
Microphone

phidgets.com Model 1067_0
Homebuilt
Homebuilt

Excel, SigmaPlot or Mathematica

Sample data:

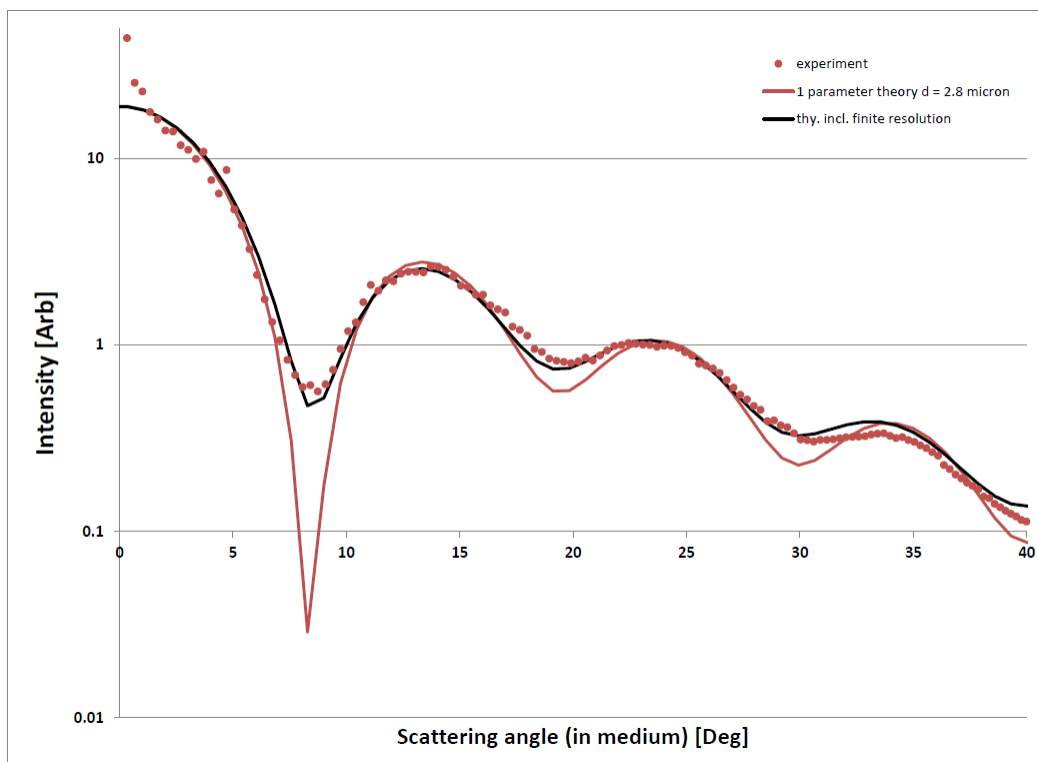

LOCK-IN AMPLIFIER

2014 Rev.

I. EQUIPMENT

- SRS Model SR830 lock-in amplifier
- Portable audio CD player with connecting wires
- Audio CD with pre-programmed signal tracks
- Oscilloscope
- Ruler / protractor
- He-Ne Laser
- Optical breadboard and various optical components
- Function Generator
- Optical Chopper
- Photodiode
- Decade resistance box
- Rectangular cuvette with polystyrene spheres
- Optical power meter
- Vernier power amplifier
- Pyrex beaker
- Microphone
- Neutral density filters
- Optical chopper

II. THEORY -- The Lock-in Amplifier

The phase sensitive or "lock-in" amplifier is a common instrument used in solving signal-to-noise problems in research laboratories. It is a very powerful instrument where signals of interest can be detected even if they are smaller than the noise signals they accompany (see fig. 1). Lock-in amplifiers are also used to detect and measure very small AC signals—down to nanovolts or smaller where noise is always a concern.

Lock-in amplifiers use a technique known as phase sensitive detection to single out the component of the signal at a specific frequency and phase. Once it does this, noise signals at other frequencies or random phases are rejected through electronic (analog lock-in) or software (DSP lock-in) filtering.

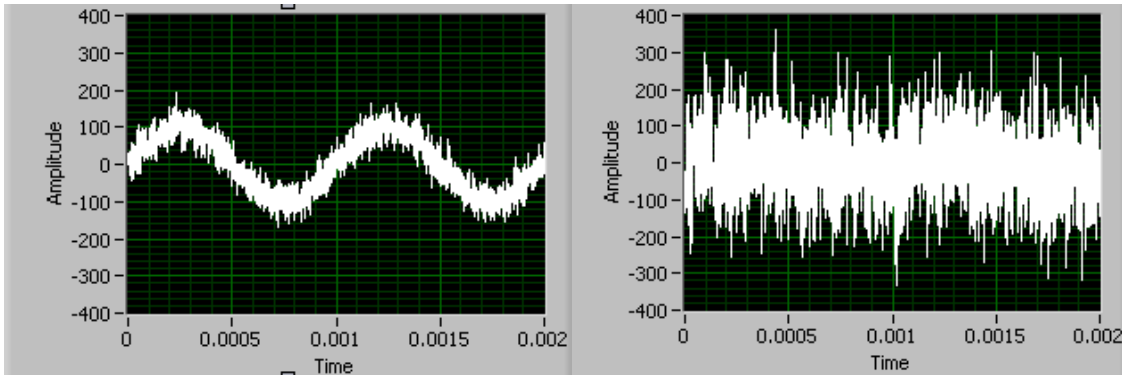

Figure 1: Both oscilloscope traces contain a sine wave signal. Although the signal on the left can be clearly seen, precise visual determination of the amplitude is obscured by the noise. The signal on the right, however, is totally “buried” in the noise. A lock-in amplifier would be able to accurately measure the amplitude of both of these signals.

An example of the power of the lock-in amplifier

Suppose a signal of interest is a $1\ \mu\text{V}$ sine wave at 10 MHz. When considering the smallest signals you can see on a traditional oscilloscope, clearly some amplification of this signal is required. A good low noise amplifier typically has about $3\ \text{nV}/\sqrt{\text{Hz}}$ of input noise inherent to the device. If this amplifier bandwidth is 200 MHz and the gain is 1000, then we can expect our output to be 1 mV of sine wave signal and 43 mV of broadband noise ($43\ \text{mV} = 3\ \text{nV}/\sqrt{\text{Hz}} \times \sqrt{200,000,000\ \text{Hz}} \times 1000\ \text{gain}$). Like the right side of figure 1, we won't have much luck measuring the 1 mV output in the 43 mV of noise unless we narrow our search to the frequency of interest.

Now using a lock-in detector we can detect the signal at 10 MHz with a bandwidth as narrow as 0.01 Hz (or even narrower if you have the patience to wait). Even using a more modest 1 Hz detection bandwidth (meaning the measurement takes ~ 1 second), the output noise will be only $3\ \mu\text{V}$ ($3\ \mu\text{V} = 3\ \text{nV}/\sqrt{\text{Hz}} \times \sqrt{1\ \text{Hz}} \times 1000\ \text{gain}$) which is considerably less than the amplified signal of 1 mV. The signal to noise ratio is now 300 and accurate measurement is possible.

How does a lock-in amplifier work?

The lock-in amplifier is used to detect a modulated signal (i.e., a signal that oscillates at a well defined frequency and phase) that is typically buried in a large noise background. To do so, a reference signal (i.e. a clean sinusoidal voltage whose frequency is the same as the one that you wish to detect) is supplied into the "lock-in." This reference provides both the frequency and phase of the expected signal. To narrow its output to a small bandwidth around the expected frequency at the specified phase, the signals are multiplied together (a.k.a. mixed or demodulated). If the signal and reference are correlated their multiplication will be **positive on average** since a positive number times a positive number and a negative number times a negative number are both result in positive answers. Random noise and the reference are uncorrelated and their multiplied value will fluctuate in time and **average to zero**. A low pass filter picks out the part of the signal that is correlated with the reference essentially by **averaging the output** of the mixer, This is the lock-in output. A setting on the

low pass filter (the time constant) sets how long this averaging is done (and the inverse of the time constant is the bandwidth of the measurement).

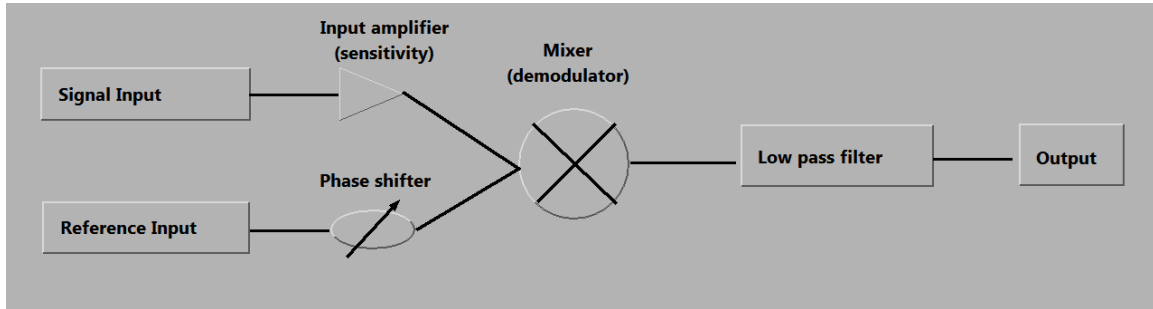

Figure 2: Block Diagram of a Lock-in Amplifier.

Lock-In amplifier Mathematics

Lock-in measurements require the input signal to oscillate at the reference frequency. Thus, typically an experiment is **excited** (or modulated) at a fixed frequency (from an oscillator or function generator) and the lock-in amplifier detects the response from the experiment. Suppose the reference signal is a square wave at frequency ω_R . This might be the sync output from a function generator. If the sine output from the function generator is used to excite the experiment, the response might be $V_I \sin(\omega_R t + \theta_I)$ where V_I is the signal amplitude.

Using the square wave, the lock-in then creates an internal reference $V_R \sin(\omega_R t + \theta_R)$ and multiplies the signal by the reference using a mixer. The mixer generates the product of its two inputs as its output V_{MI} :

$$V_{MI} = V_I V_R \sin(\omega_R t + \theta_I) \sin(\omega_R t + \theta_R), \quad (1)$$

or

$$V_{MI} = \frac{1}{2} V_I V_R \cos(\theta_R - \theta_I) + \frac{1}{2} V_I V_R \sin(2\omega_R t + \theta_R + \theta_I). \quad (2)$$

Since the two inputs to the mixer are at *exactly* the same frequency, the first term in the mixer output is at DC (time independent) or $\cos(\theta_R - \theta_I)$. The second term is at frequency $2\omega_R$, which is a high frequency and can be readily removed using a low pass filter. After filtering,

$$V_{MI+FILT} = \frac{1}{2} V_I V_R \cos(\theta_R - \theta_I), \quad (3)$$

which is proportional to the cosine of the phase difference between the input and the reference. Hence the term phase-sensitive detection.

In order to measure V_I using equation (3), the phase difference between the signal and reference, $\theta_R - \theta_I$, must be stable and known. The lock-in amplifier solves this problem by

using two mixers, with the reference inputs 90° out of phase. The reference input to the second mixer is $V_R \sin(\omega_R t + \theta_R - \pi/2)$ and the output of the second mixer is:

$$V_{M2} = \frac{1}{2} V_I V_R \cos(\theta_R - \theta_I - \pi/2) + \frac{1}{2} V_I V_R \sin(2\omega_R t + \theta_R + \theta_I - \pi/2). \quad (4)$$

After filtering,

$$V_{M2+FILT} = \frac{1}{2} V_I V_R \cos(\theta_R - \theta_I - \pi/2) = \frac{1}{2} V_I V_R \sin(\theta_R - \theta_I). \quad (5)$$

The amplitude and phase (compared to the reference) of the input signal can be determined from the two mixer outputs, equations (3) and (5). The result is:

Amplitude:
$$R = (2/V_R) \sqrt{V_{M1+FILT}^2 + V_{M2+FILT}^2} \quad (6)$$

Phase:
$$(\theta_R - \theta_I) = \tan^{-1} \left(\frac{V_{M2+FILT}}{V_{M1+FILT}} \right) \quad (7)$$

Units: RMS or Peak?

Lock-in amplifiers as a general rule measure the input signal in Volts rms. When the lock-in displays a magnitude of 1 V (rms), the sine component of the input signal at the reference frequency has an amplitude of 1 V_{rms} or 2.8 V_{pk-pk}. This is important to remember whenever the input signal is *not* a sine wave. For example, if the signal input is a square wave with a 1 V_{pk} (2 V_{pk-pk}) amplitude, the sine component at the fundamental frequency has a peak amplitude of $4/\pi \times 1$ V_{pk} (this result uses a Fourier expansion of the square wave). The lock-in displays the rms amplitude (1 V_{pk}/ $\sqrt{2}$) or about 0.9 V_{rms}.

Units: Degrees or Radians?

In this discussion, frequencies have been referred to as both f [Hz] and ω [radian/sec], as they are related through,

$$\omega = 2 \pi f. \quad (8)$$

This is because it is customary to measure frequency in Hertz, while the math is most convenient using ω . For purposes of measurement, the lock-in reports frequency in Hz (or kHz etc.). The equations used to explain the calculations are often written using ω to simplify the expressions.

Phase is always reported in degrees. Again, the equations are usually written as if θ were in radians.

III. PROCEDURE

A. Getting familiar with the lock-in using a LabView simulation

Your first task in this section of the lab will be to become familiar with some of the basic controls on the lock-in amplifier. Open the LabView VI `lockin_dual_phase.vi` from the classes folder. Right away when the VI opens you will see a sinusoidal signal with randomly generated noise, and a clean reference signal at the same frequency and phase. Next, the output of the mixer is shown. Clearly it has a DC offset, a time varying (at twice the frequency) component and also random noise. The low pass filter picks out the DC component (a.k.a “signal X” from equation 3 above). This value is plotted on the graph at the right. “Signal Y” (eqn. 5) is also generated in the block diagram. Its digital value is shown on the right hand side of the VI. These signals are combined on dual phase lock-in amplifiers (and DSP lock-ins like the SR830) to give the amplitude “signal R” and the phase “signal θ ” of the desired measurement.

Run the VI continuously and play with the controls in order to fully understand the lock-in amplifier. Note especially how the noise level and the time constant affect the output stability and how the signal amplitude and reference phase affect the output values.

When you are comfortable with this VI, open `lockin_unknowns.vi` from the classes folder and complete your prelab exercise.

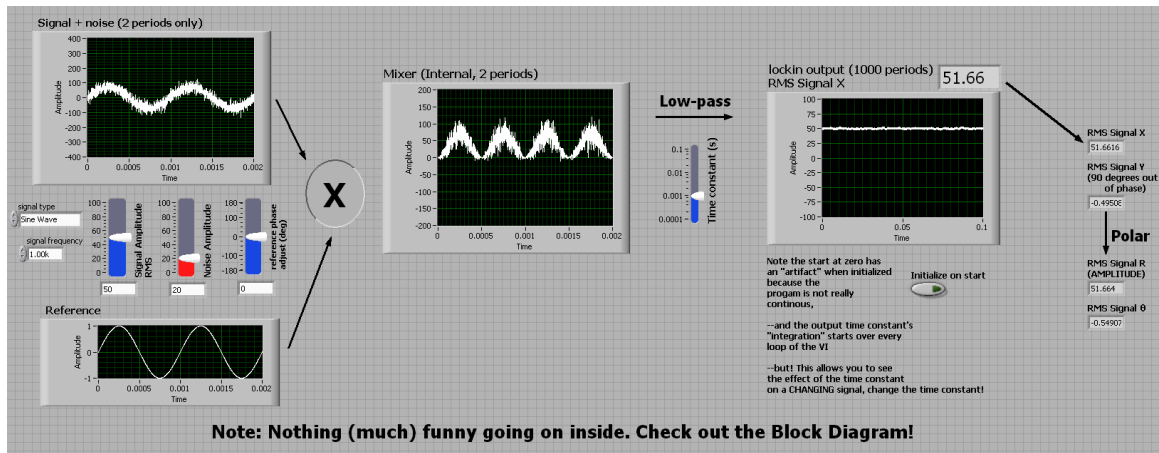

Figure 3: `lockin_dual_phase.vi`

B. Comparison of the Lock-In Amplifier to the Oscilloscope for a simple sine wave

You will do this by directly comparing a simple sine wave from a function generator, as measured using the oscilloscope, to the corresponding measurements taken with the lock-in amplifier.

Using a pair of BNC tees, attach the output of the function generator to both the “A” input on the lock-in as well as the REF IN connector and one of the channels on the oscilloscope. Set the function generator so that it generates a signal with a frequency in the

range from about 300 – 600 Hz, with a peak-to-peak amplitude of about 0.5V (as measured on the scope).

Turn to the page in your lab handout labeled “**SR830 Lock-In Amplifier Settings and Operation**”. Carefully work through all of the settings on the lock-in amplifier. Record in your notebook the Reference Frequency, Reference Phase and Output as measured using the lock-in amplifier. Compare the frequency and output values to those measured directly by the scope, after making suitable peak-to-peak to RMS conversions. They should be very similar. Since you are using the same signal from the function generator for both the input and reference signals, the lock-in phase measurement should be very close to zero.

C. Determination of Signal-to-Noise Ratio in Audio Tracks

You have been provided with an audio compact disc (CD) on which a number of tracks have been prerecorded. Each track is in stereo, with a reference (pure sine wave) signal in one channel (yellow wire) and the “noisy” signal in the other channel (red wire) with the green wire being ground. The signals to be studied will have varying amplitudes, frequencies and phases, and will also contain a variable amount of random noise. Your job is simply stated: *For each CD track, determine (if possible for that track)*

- *amplitude of the signal using BOTH the lock-in and the oscilloscope.*
- *frequency of the signal*
- *the phase difference between that signal and the reference signal*
- *amplitude of the noise*
- *the signal-to-noise ratio*

Use only the CD that has been provided as you will be graded on **correctness** of your answers. **Be sure to adjust the volume of the CD player so that it is turned all the way up**, otherwise your answers will not match the known values.

To do this, using BNC tees, connect the reference and signal channels so that they go into both the scope inputs and also to the appropriate inputs on the Lock-In amplifier. Study the tracks of the CD. There should be tracks where the signal is clearly evident, and those where the signal is entirely buried in the noise. For the desired measurements you will need to use both the scope and the lock-in, although some will be easier, harder, or impossible to do with one or the other.

Whenever possible, compare the amplitudes of the signal obtained using the lock-in and the scope. Your report should explain fully how you used the combination of instruments to determine the measurements you take. Be particularly careful of RMS versus peak-to-peak values. You should also experiment with (and determine the impact of) settings like sensitivity and time constant on the lock-in amplifier’s output reading. Explain these in your report. Your measurements using the oscilloscope (when possible) and lockin amplifier (on all tracks) **should match**; make sure this is true.

D. Using the lock-in as a frequency response device

The lock-in can also be used to measure the response (frequency and phase) of a driven object. As you have seen in previous classes, a driven oscillator exhibits maximum amplitude response at resonance. Also, the phase of the response changes dramatically around resonance. We will use the lock-in to measure the resonance frequency of a glass beaker.

Put the SR830 in internal mode for the reference by pressing the source button. Set the amplitude to 5V. Attach SINE OUT to the power amplifier and the power amplifier to an audio speaker. Place the speaker next to the beaker and a microphone near the top glass wall. Connect the microphone to an oscilloscope and ping the glass with your finger. Use the oscilloscope to get a rough estimate of the resonance frequency. You may have to adjust the oscilloscope trigger to see the 'pure' sine wave that results after other transients die down.

Now turn on the lock-in and power amplifier near but below this frequency and measure the beaker's response for a number of frequencies across the resonance. Note: these beakers can have a rather sharp resonance, so make sure that you take spaced points to **clearly** show resonance behavior. Be sure to report on the response and discuss whether the beaker behaves as expected for a driven oscillator (see your mechanics or introductory texts). Another note: many beakers have two very closely spaced resonances, if you see evidence of this do not be surprised, and take data to show both resonances.

E. Determining the Attenuation in Neutral Density Optical Filters

You are now ready to investigate the attenuation in neutral density optical filters, which for large attenuations becomes a precision measurement that requires the lock-in. Earlier in the term, you used these filters in the interferometer lab to produce a beam of light containing roughly one photon at a time in the path of the interferometer.

Recall the definition of a neutral density filter. Incoming light is attenuated by a fixed ratio regardless of input power and wavelength. An expression for the density, ND, of the filter is

$$P = P_0 10^{-ND}, \quad (9)$$

where P_0 is the input power, and P is the power transmitted. Ideally, the filters do not depend on the wavelength of light used. Real neutral density filters do, in fact, depend on the wavelength of light. The ND label on the filter is an approximately an average over the (in this case) visible part of the spectrum. We will use the lock-in to accurately measure the attenuation of the filters for the He-Ne (632 nm) laser light used in lab. To do so follow these steps:

- Using a power meter, measure the power produced by the He-Ne laser. This is the power 'input' to the filter.

- Place a ND1 filter in front of the power meter, then measure the ‘output’ power.
- What is the largest ND you can still accurately measure with the power meter? How do you know this is the largest? Does it matter if the lights are on or off? Do this measurement, and be sure to include errors.

To measure very low light signals we will now use the lock-in amplifier. An optical chopper is a device that blocks and passes a light beam at a set frequency by spinning a blade that has slots cut in it. The frequency can be set directly with a knob on the controller. The control box actually measures the rate the light is blocked using the photo sensors on the chopper head and adjusts the motor to produce the correct chopping frequency. The chopper also gives a convenient TTL signal at the same frequency (but not necessarily phase) as the optical chopping that can be used as the reference to the lock-in.

- Set up a photodiode to measure the incident power. Since the photodiode produces current as its output, you must terminate the photodiode.
- Measure the voltage produced when the laser directly strikes the photodiode. Make sure that you terminate the photodiode in a reasonable resistance so that the full output of the laser produces somewhat less than the 0.5 V maximum that the SR830 can handle.
- Put the SR830 back into external reference mode.
- Set up the optical chopper between the laser and the detector. Pass the reference and the photodiode signals to the lock-in amplifier and the oscilloscope. Set the frequency of the chopper and start the blade spinning. (Think carefully what frequency you want to chop the beam at, and justify this choice.)
- Without a filter in the beam path (full power) measure the photodiode signal on both the oscilloscope and the lock-in amplifier. **As you found with the CD player tracks, you should be able to make these measurements agree with one another.** (Note: see section “Units: RMS or Peak?” because the signal should now be a square wave between 0 and a positive voltage.)
- Now repeat the measurements (including error bars) for the ND1 filter.
- Make measurements as you add ND1 filters.
- What is the largest ND filter you can accurately measure now? Again, does it matter if the lights are on or off? Again, how do you know it is the largest?

F. Mie scattering

The same setup used in the previous section can now be used to measure the scattering from small spheres in a colloidal liquid. When the particles are much smaller than the wavelength of light (e.g. atoms) familiar Rayleigh scattering gives a simple answer for the angular and wavelength dependence of the scattering. The wavelength dependence of this result, for example, determines why the sky appears blue. For particles that are much larger than the wavelength of light (glass marbles or other ‘large’ objects e.g.), conventional optics (i.e. ray tracing) is used to determine the path of light. When the particle size and the wavelength of light are comparable, however, the mathematical solution to the problem becomes quite difficult. Still, exact solutions can be found in certain cases. In our case, we will be using small spheres suspended in water to scatter light. If the

solution of spheres is dilute enough, light will only have scattered a single time before exiting the water and reaching a detector. The solution to this and several similar situations (e.g. water droplets in clouds) has an exact solution and is called Mie scattering after German physicist Gustav Mie.

As with any scattering experiment there are several scattering parameters that determine the scattering amplitude (light intensity received at the detector). Here, the scattered intensity will depend on the size and composition of the particle as discussed, the scattered angles (both azimuthal and polar), and also the polarization and wavelength of the light.

The final goal for this week is to set up the optics necessary to measure He-Ne laser light scattering from our dilute sphere sample in a test tube of water and to take measurements by hand for a few angles.

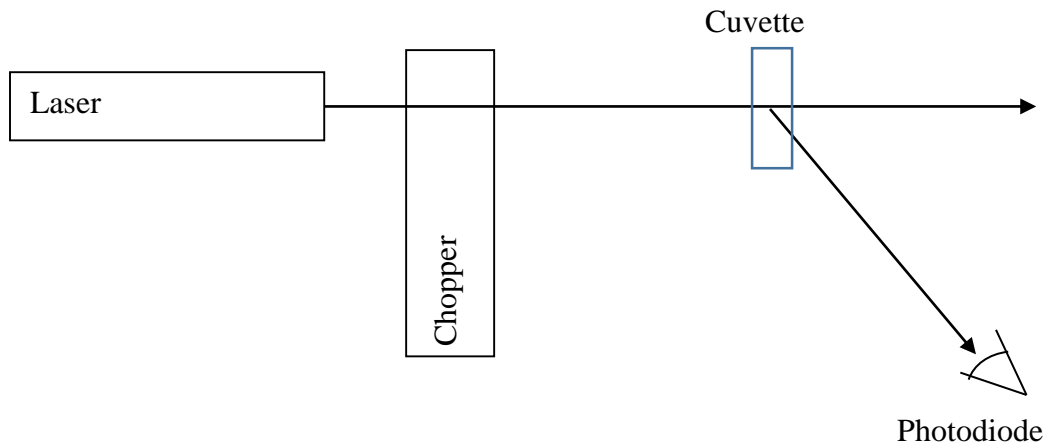

Figure 4: Setup to measure Mie scattering intensity.

- From your ND filter optical attenuation setup, replace the filter with the test tube filled with water and the scattering spheres.
- Measure the intensity of scattered light as a function of polar angle as shown in figure 4 by manually moving the photodiode around the optical table and using a protractor.
- To see the important features, use a sheet of paper placed after the test tube. Do this to choose the angles you wish to measure.
- Do the scattered intensities have the same form as Rayleigh scattering? (The Rayleigh scattering intensity has a $I(\theta)=1+\text{Cos}^2(\theta)$ dependence.) Why or why not?

In your write-up, qualitatively discuss your results including making graphs, and compare these to the predictions of Rayleigh scattering.

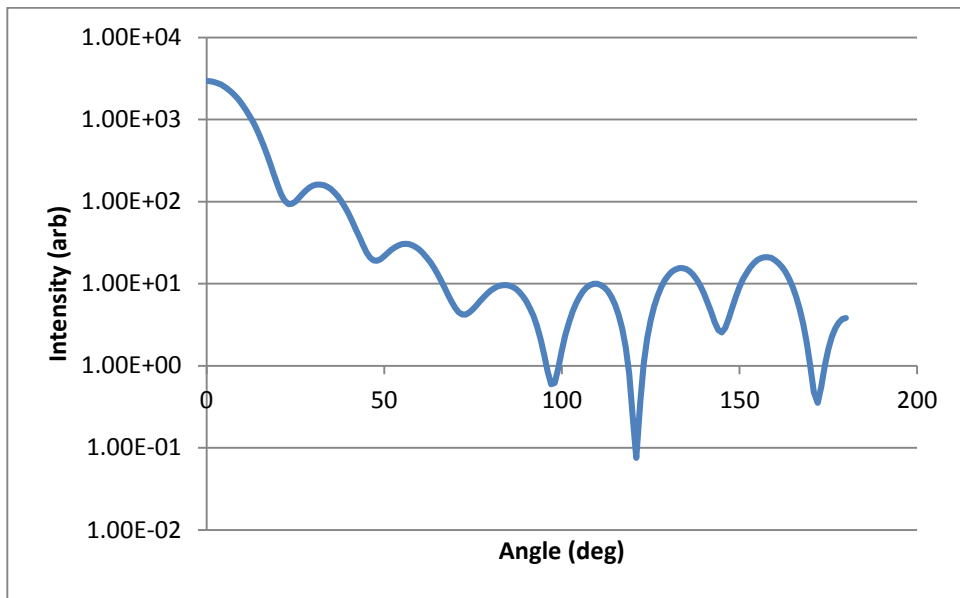

Figure 5: Typical Mie scattering intensity versus angle. Note the log scale intensity (arbitrary units) axis. Intensity maximum is in the forward direction (zero degrees) and decreases with several minima for increasing scattering angle. The intensity pattern can change drastically for many experimental reasons.

SR830 Lock-In Amplifier Settings and Operation

For manual operation of this model, use the following settings:

Signal input

Input: A
Couple: AC
Ground: Float

Filters

Line: Off
2 x Line: Off

Channel One

Display: R
Offset: Off
Ratio: Off
Expand: Off

Channel Two

Display: θ
Offset: Off
Ratio: Off
Expand: Off

Reference

Phase: 0 deg
Trig: Sine for Sine waves, Pos Edge for TTL
Source: Internal Off (external source)

Sensitivity

Sets the maximum signal before internal overload
Set to smallest value before red OVLD light turns on

Time constant

Sets bandwidth of the measurement
Set to longest you are willing to wait between measurements

IV. References

1. SRS Model 844 Lock-in Amplifier Manual, Stanford Research Systems, ©1977
2. Perkin-Elmer Technical Note TN1002, "The Analog Lock-in Amplifier", <http://www.cpm.uncc.edu/programs/tn1002.pdf>
3. I. Wiener, M. Rust, and T.D. Donnelly, Am. J Phys. **69** (2), 129-136 (2001).

Experimental Automation Using a Lock-In Amplifier and Motion Control: Mie Scattering Experiment

2014 Rev.

The goal of this write-up is to describe how to use LabVIEW to control the SR830 Lock-In amplifier for the readout of lock-in data and also for controlling a stepper motor. This will enable automated measurements of scattering intensity curves for an optical Mie scattering experiment.

Automating data collection is important in many ways. First it facilitates the collection of *more* data, through the reduction in time and effort required for each data point. Second it allows for more *precise* data, by eliminating the human component through the control of fine instruments for setting experimental conditions. It also reduces errors and variations in the recording and storage of the data.

From your Mie scattering curves last week you should have found there are only a few steps for collecting each data point.

1. Set the detection angle by moving the detector and reading the protractor
2. Set the sensitivity (gain) control on the lock-in amplifier
3. Set the time constant on the lock-in amplifier
4. Record the amplitude and phase determined by the lock-in amplifier

These steps were then repeated for an intensity measurement at several angles.

Your goal this week is to automate this procedure. You will do this by writing a VI that communicates with and controls the various instruments, and writes the data to a file.

Automation of the experiment

0. To begin, restore the Mie scattering setup that you had at the end of last week.
1. The first step in the automation process is the setting of the scattering angle. We will do this using a “stepper motor,” an electric motor that can actuate rotation in precise steps (angles). By attaching an arm holding the photodiode to the stepper motor and placing the axis of rotation directly below the scattering center, we can set the detector’s angle relative to the laser beam by simply rotating the motor.

Attach the stepper motor to its controller **FIRST** and the controller to the computer in the USB slot **SECOND**. This order is always important with stepper motors in order not to damage the controller. Power may then be applied to the controller. Be careful that the cables do not get bumped during the experiment; move the computer if necessary. Also, to disconnect the device, remove the power first then the USB cord second. Never disconnect the motor from the controller when it is on.

Phidget Stepper Controller Wiring Connections

A = Green motor wire

B = Black

C = Blue

D = Red

G = power supply ground

+ = +12VDC

The communications between the motor controller and the computer is similar to the GPIB communications you have done earlier in this course, and is not difficult. However, learning a new communication style is not the intended goal for this experiment (and you will be automating the lock-in using GPIB later), so your instructor has created a subVI to allow LabVIEW to communicate with the motor controller. This subVI is titled “move_phidget.vi” and is found in the advlab folder on the physics network. Operation of this subVI will move the motor in user defined steps in either direction. Each step is a rotation of the motor shaft by a fixed angle.

To use the motor, securely attach the stepper motor to the optical table and the detector arm to the motor shaft. Open the VI “move_phidget.vi”, found in the advanced lab folder and read all of the warnings and notes there. Also make sure motion of the motor will not cause collisions, and the wires will not get tangled in the arm.

Once you are sure the motor is securely attached and connected, run move_phidget.vi to see the motor move. Note that the motor cannot handle a lot of torque, so bumps to the arm or cable tension on the photodiode can possibly move the arm in undesired ways.

Using move_phidget.vi, determine the number of steps to complete a full revolution of the motor (and arm) and thus determine the angular resolution of a single step of the motor. You will use this when you take data at many angles.

2. The next step is to combine this movement with steps to control and read out the lock-in amplifier. You can do this by making a VI that utilizes a flat sequence structure and does your desired steps in order. The first frame in the sequence should contain move.vi with the appropriate controls to that subVI. The next frames should communicate with the SR830 via GPIB.

In the GPIB Experiment Control and Franck-Hertz experiment earlier in this course you had the benefit of using a subVI that did the low level GPIB commands for you. In this experiment, you will do these commands yourself. See tables 1, 2, and 3 at the end of this write-up for values and commands for the SR830.

Some notes about communicating via GPIB are now due. The GPIB write and GPIB read functions are found in the “instrument I/O->GPIB” menu of the functions palate. Hint: the GPIB menu has the number 488 on it. In LabVIEW, the GPIB address is a string with the number set on the corresponding instrument. The ‘data’ field is either the ASCII

string you wish to send or the string that is read from the instrument. Also, whenever you want to ask the instrument for something you always follow a write with a read. If you do not, the output buffer on the instrument will not clear. Then, the next reading will either give an error or will give the answer for a previous query.

For the same reason, on the GPIB read function if you do not know exactly the number of bytes you will be reading set it to a number that is larger than the expected size (think of it as a maximum expected size). Do this to make sure the entire response is read and the buffer is cleared successfully. 100 bytes should be more than sufficient for us.

As an example, Figure 1 below sets (on channel 8) the SR830 lock-in sensitivity to 20 nV (code 3 from table 1), then reads out the current sensitivity value to double check correct operation. You may find it useful to use the functions “Fract/Exp String To Number” and “Number to Decimal String” to convert to/from the string format. These can be found in the Programming->String->String/Number Conversion menu. Finally, you may need to add a delay between frames if any of the operations, such as changing the sensitivity, take a substantial amount of time (as done below).

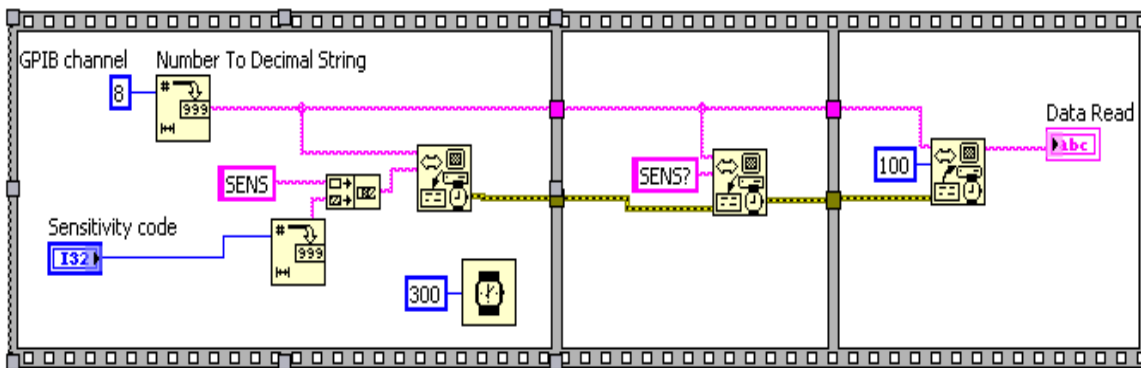

Figure 1: Example of a flat sequence which sets and then queries the sensitivity value on a SR830 set to GPIB channel 8. The “Number to Decimal String” nodes are handy but not necessary to execute simple code such as this. You may choose to use this and also a string to number converter in your program.

- IMPORTANT: Figure 1 is NOT the VI you will construct**, but is an example of how to communicate with the lock in. Now is the time to think critically about the operations you wish to perform and their sequence. Certainly you will wish to query and read an output. Do you want to set the gain or time constant, or do an auto-gain? Do you wish to do this once, or for every measurement? How much do you want to move the motor?

CRITICAL TASK: Once you determine what operations you wish to perform, code the LabVIEW to perform your tasks to give a single measurement. Remember that you should always verify that your VI works AS YOU EXPECT, giving/saving the CORRECT values that are shown on the front of the lock-in.

5. Next, make this a SubVI that is usable within other VI's by setting appropriate inputs and outputs to the connector pane. Save your result.
6. Open the VI that you used for the Franck-Hertz experiment, and save it under a new name. As you recall, this VI controls the experiment inside a for loop to set voltages, read values, graph results, and save data to a file. Replace the subVI inside this program using the one you made above, and modify this program to now perform multiple measurements. As in step 4 above, it is up to you to think about the modifications necessary so the experiment is carried out how you want.
7. At this point, you should have a working VI and are in a position to automate the experiment that you did last week! A reminder: be sure to save and document what you have done in your notebook.

Mie Scattering

1. For your first scan, manually place the detector arm where you wish to start, and do only a few motor steps. Run the program, and make sure that you verify the output saved in your text file. Tip: you may also wish to save in this file the sensitivity and time constant codes you set.
2. Now you are finally ready to do some production runs! First, determine how to find the absolute scattering angle relative to the laser beam. Zero degrees is in the forward direction. Hint: you may have realized that the largest intensity is directly in front of the laser (zero degrees). You may wish to use this to your advantage (in each and every scan). Remember that in all your reported data, zero angle should be measured with respect to the forward direction of the laser.
3. Subsequent runs should hone in on features that are found in last week's figure "Typical Mie Scattering Intensity" and give a complete and precise reading of your sample. (Although the plot given there is NOT the same as the data you will take this week.) Your final data sets (and graphs in your lab book) should clearly show Mie scattering behavior.
4. Although it is your job to design and carry out the experiment (step three above), you may have your instructor to look at your data set and you may politely ask if you are forgetting anything.

Data Analysis

1. If the size of the object is much larger than the wavelength of the light, then diffraction theory gives a solid prediction for the angle of the first minimum (recall the theory for minimum angular resolution in telescopes). Even though this is not strictly the case for us we can still use the formula to obtain an estimate for the sphere size. Rayleigh's criterion for the first diffraction minimum is

$$\sin(\theta) = \frac{1.22}{d} \frac{\lambda}{n_{med}}, \quad (1)$$

where θ is the angle of the first minimum, λ is the wavelength of the light, d is the diameter of the object and n_{med} is the index of refraction of the medium containing the scattering particles. Do this estimate. Is your result at least 100 times the size of the wavelength? Although the answer is (should be) no, this estimate should still be within a factor of four of the correct size of the spheres!

2. The biggest effect that is skewing your results is Snell's law because the scattering takes place in a rectangular test tube filled with water and the beam transitions to air to travel to the detector. Use Snell's law to correct for this and your final answer for this week should be within a factor of two of the correct answer. Congratulations, you are on your way to becoming a precision measurement physicist.
3. Finally, make a plot of scattering intensity as a function of angle (in water) that clearly shows your result (i.e. publication quality). You will use this plot next week.

| <u>Code</u> | <u>Sensativity</u> | <u>Code</u> | <u>Sensativity</u> |
|-------------|--------------------|-------------|--------------------|
| 0 | 2 nV/fA | 13 | 50 μ V/pA |
| 1 | 5 nV/fA | 14 | 100 μ V/pA |
| 2 | 10 nV/fA | 15 | 200 μ V/pA |
| 3 | 20 nV/fA | 16 | 500 μ V/pA |
| 4 | 50 nV/fA | 17 | 1 mV/nA |
| 5 | 100 nV/fA | 18 | 2 mV/nA |
| 6 | 200 nV/fA | 19 | 5 mV/nA |
| 7 | 500 nV/fA | 20 | 10 mV/nA |
| 8 | 1 μ V/pA | 21 | 20 mV/nA |
| 9 | 2 μ V/pA | 22 | 50 mV/nA |
| 10 | 5 μ V/pA | 23 | 100 mV/nA |
| 11 | 10 μ V/pA | 24 | 200 mV/nA |
| 12 | 20 μ V/pA | 25 | 500 mV/nA |
| | | 26 | 1 V/ μ a |

Table 1: Sensitivity values for the SR830 Lock-In Amplifier

| <u>Code</u> | <u>Time Constant</u> | <u>Code</u> | <u>Time Constant</u> |
|-------------|----------------------|-------------|----------------------|
| 0 | 10 μ s | 10 | 1 s |
| 1 | 30 μ s | 11 | 3 s |
| 2 | 100 μ s | 13 | 10 s |
| 3 | 300 μ s | 12 | 30 s |
| 4 | 1 ms | 14 | 100 s |
| 5 | 3 ms | 15 | 300 s |
| 6 | 10 ms | 16 | 1 ks |
| 7 | 30 ms | 17 | 3 ks |
| 8 | 100 ms | 18 | 10 ks |
| 9 | 300 ms | 19 | 30 ks |

Table 2: Time constant values for the SR830 Lock-In Amplifier

| <u>Command</u> | <u>Action</u> |
|----------------|---|
| FREQ? | Queries the reference frequency |
| SENS i | Sets the sensitivity to code i |
| OFLT j | Sets the time constant to code j |
| AGAN | Performs the auto gain function |
| OUTP?1 | Reads the value of X |
| OUTP?2 | Reads the value of Y |
| OUTP?3 | Reads the value of R |
| OUTP?4 | Reads the value of θ |

Table 3: Partial command list for the SR830 Lock-In Amplifier

References

1. I. Wiener, M. Rust, and T.D. Donnelly, Am. J Phys. **69** (2), 129-136 (2001).
2. John R. Taylor, "An Introduction to Error Analysis." University Science Books (1997).

Mie Scattering Revisited and Data Analysis

Week 3

2014 Rev.

Prelude

In the last lab, you used the lock-in amplifier and automation techniques to precisely measure the scattering intensity of polystyrene spheres in water. This week, we revisit that lab with one goal in mind: to take publication quality data and do publication worthy analysis for use in your final paper. This goal is a lofty one, and as such it forms the capstone for this course.

Completion of this task is even more self-directed than the initial data taking you performed last week. Although you will begin this process in lab, you may continue work until the last day of classes when both the lab notebook and paper are due. Even still, based on previous experience, you should strive to finish taking data and begin the analysis midway through the first day. Finally, in the lab and until the due date, do not hesitate to ask your instructor if you have questions about the process.

Generally, the steps you will take are:

- To correct any mistakes or complete taking data as noted in your returned lab book.
- To investigate other effects that would make your measurements ‘better’ or take measurements needed for the analysis or its justification.
- To perform a theoretical analysis of the scattering allowing a determination of the size of the spheres to 0.1 μm and a justified error bar for the size.

Experimental Enhancements

Last week you precisely measured the scattering intensity from a sample provided to you by the instructor. Now is the time to look at that data, think critically about your experiment, and determine what additional measurements you need to make to make your overall measurement publication quality. Various things to consider can come from class, previous experiments, or talking with your instructor. Be sure to at least consider things such as:

- Finite detector geometry
- Various noise sources
- Digital resolution and gain scales
- Error bars
- Error propagation
- Background sources
- *Careful* alignment
- Laser polarization

Although you want to be complete, try to finish data taking by midway through the first day so you have time to start the analysis.

Mie Scattering Theoretical Curve

Last week you used Rayleigh's criterion to estimate the size of the polystyrene spheres. This estimation is crude because the wavelength of the light is of similar size as the spheres. A fuller analysis uses Mie theory to determine the size of the spheres. As mentioned in class and the previous write-ups, the full Mie theory is quite complex, if you are interested see reference 1. There are, however, a few easy-to-use tools that will calculate Mie scattering amplitudes with only a minimum of input. Several can be found on the internet by searching for "Mie scattering calculator." We will be using a software program called MieCalc. This program can be found in the advanced lab folder. The java applet is called miecalc.jar.

When MieCalc is opened an example of scattering from water droplets in air (i.e. clouds) is preloaded. If you press the plot button, you can see a typical pattern for scattering of green light from a 100 μm water droplet in air (use log y-axis to see the pattern more clearly). For our situation you may use the following information: $n_{\text{water}} = 1.33$, $n_{\text{polystyrene}} = 1.59$. The 'imaginary index' describes how the spheres absorb light; since our spheres are nearly transparent, you can set this to zero. The final input to the program in order for it to calculate the scattering curve is the diameter of the spheres. If you plug in a value, it will calculate a theoretical curve rather quickly. Unfortunately, the diameter is what you are trying to determine!

While it would be nice to be able to input the scattering curve you measured, and have a program output the size of the sphere, unfortunately, in this case (and in many, many others) the theory is too complex to do this kind of reverse determination. To do the job, then, you need to *find* the theoretical scattering curve that *best fits* the experimental curve by varying the diameter.

Chi-squared

You may recall the procedure which compares a theoretical curve to an experimental curve is called a chi-squared (χ^2) fit. Smaller χ^2 corresponds to better fits. Thus the 'best' value of the size will have the smallest χ^2 value.

To find a place to begin, use a "chi-by-eye", on your data and the theoretical curve. Because the human brain is fairly good at matching patterns, a visual comparison of the data without calculating the χ^2 statistic is actually a decent technique for determining a best fit. This visual comparison is a "chi-by-eye". If you like, you can concentrate on the angle of the first minimum and first (not at zero angle) maximum of the scattering intensity. In the program, vary the sphere diameter and look at the graph of

Mie scattering magnitude versus angle, and the accompanying data, until these points match the measured points to within one degree. A convenient way to tell what varying the sphere size does theoretically is to use the overplot feature of MieCalc. This procedure alone should tell you the size of our spheres to within one micron. Note: if your data does not seem to agree no matter what you do, make sure that you have set the zero angle of your measurements, and have adjusted it for Snell's law as described last week.

To determine the size of the spheres to a finer precision, and to generate and justify your error bar you need to calculate χ^2 . From your notes in your first year physics class, and found in reference 2, Chapter 12, is a discussion of the chi-squared technique. Basically, χ^2 compares each point on the measured curve and compares to theory. If, for the whole distribution, the measurements tend to agree, then the theory is a good fit. The equation for χ^2 (c.f. eqn 12.11 ref. 2) is,

$$\chi^2 = \sum_1^n \left(\frac{\text{obs.} - \text{thy.}}{\sigma} \right)^2,$$

where the sum is over each measured point (obs) with its corresponding theoretical calculation (thy) and σ is the uncertainty in that particular measurement. For a good fit, on average the observed values will deviate from theory by one standard deviation. This implies that each term in the sum will be close to one and χ^2 will be close to the number of data points, or n (for *good* fits). For poor fits the data will vary much more producing a larger χ^2 . Since you have a measured curve, and a way to generate the theoretical curve, you are in a position to determine statistically whether the fits agree. Unfortunately, there are three more complications you need to deal with.

First, due to the complexity of the situation, the measurements you took are unlikely to statistically agree with *any* of the theoretical curves you generate. Depending on the measurement effects you investigated above, and thus the overall quality of your data, the agreement can be quite poor.

(In effect, the statistical error bars σ for each of the data points found in measurement are ignoring systematic effects. In this case, it is entirely possible that only a few points are dominating in their contribution to χ^2 and special scrutiny should be placed on these points.)

In this case, the *qualitative* behavior of χ^2 (rather than the actual p-values) will determine the result. Here, the best fit theoretical curve (i.e. the one with the smallest χ^2) still determines the best determination of the size even if its p-value is absurdly small. To determine the error bar *on the diameter for the sphere*, we will find the theoretical curve that doubles the minimum value found.

Second, since the angles at which your intensity measurements were taken are not at the same angles as your theoretically calculated intensities (due to the Snell's law correction and the functionality of MieCalc). Thus they cannot be directly compared

(subtracted from one another in χ^2). To account for this we will cheat (just a little) by interpolating the theoretical curve generated by MieCalc.

(This would be “easy” to fix if MieCalc could input a list of points with which to calculate the theoretical intensities. Any of you want to explore your programming abilities?)

Linear interpolation is easy understand. If you have two points ((x,y) pairs) you know, and want to guess where the y value of a point between them (in x) lies, draw a line between the points to find the corresponding y value. Interpolation can be done in easily in SigmaPlot, Mathematica, Excel and other programs. It is up to you to choose a program and figure this out.

Third, the theoretical intensities from MieCalc are not normalized to our sample. What this means is that the sample concentration and thickness affect the overall intensity of the measurements. Hopefully, we are in a linear regime where doubling either concentration or thickness doubles the scattering intensity as all angles (this is one of the experimental controls you should have tested above). Thus to account for this, you have to manually adjust the MieCalc output to produce the “best” intensity. In essence you are doing *another* χ^2 fit. Here, when you are calculating χ^2 with your measurements you are free to manually adjust the overall intensity of the theory by multiplying by a constant. Mathematica can do this process automatically if you wish

End Notes

In the end, you should have a best fit and an error bar for the diameter of the polystyrene spheres. Accompanying this should be plot with the data and the best fit theoretical curve (publication quality). Also, a plot of χ^2 vs. diameter of the polystyrene sphere is required to justify your error bar. Even though the lab is more self-directed and concentrates on analysis, be sure that your lab book is complete as discussed throught the term. In all cases, make sure your thought process, methods, and analysis are clear in both the written report and in the lab notebook. Good luck!