

Equipment Needed from ORTEC:

- 556 High Voltage Bias Supply
- 4001A/4002D NIM Bin and Power Supply
- 996 Timer and Counter
- C-36-12 Cable
- C-24-12 Cable
- C-24-1 Cable
- C-29 BNC Tee Connector

Other Equipment Needed:

- End-Window Geiger Tube
- GM Pulse Inverter
- Sealed Beta and Electron Conversion Sources (Disk Type) 1–5 μCi , ^{204}Tl , ^{207}Bi , ^{137}Cs , ^{113}Sn (substitute alternate sources with similar energies)
- Sealed Solid Disk Gamma Ray Sources $\sim 1 \mu\text{Ci}$, ^{137}Cs , ^{60}Co , ^{22}Na , ^{65}Zn , ^{54}Mn (substitute alternate sources with similar energies)
- Short Half-Life Beta Source or Mini-Generator
- RaD and E Split Check Source Set; ^{210}Pb and ^{210}Bi , $\sim 1 \mu\text{Ci}$, should include blank-half to retain geometry when using either half alone.
- Oscilloscope
- Absorber Foil Kit containing 10 lead absorbers from 800 to 8000 mg/cm^2 and 20 aluminum absorbers from 0 to 3000 mg/cm^2
- Stand for GM Counter; contains GM Tube and stand with 6 counting levels

Purpose

The purpose of this experiment is to familiarize the student with the Geiger-Mueller counter. This counter is a widely used pulse-counting instrument that uses gas amplification, which makes it remarkably sensitive, but whose simple construction makes it relatively inexpensive. The experiments that are designed to accomplish this purpose deal with the operating plateau of the Geiger tube, half-life determinations, resolving-time corrections, and the basic nuclear considerations involved.

Description

Basically, the Geiger counter consists of two electrodes with a gas at reduced pressure between the electrodes. The outer electrode is usually a cylinder, while the inner (positive) electrode is a thin wire positioned in the center of the cylinder. The voltage between these two electrodes is maintained at such a value that virtually any ionizing particle entering the Geiger tube will cause an electrical avalanche within the tube. The Geiger tube used in this

experiment is called an end-window tube because it has a thin window at one end through which the ionizing radiation enters.

The Geiger counter does not differentiate between kinds of particles or energies; it tells only that a certain number of particles (betas and gammas for this experiment) entered the detector during its operation. The voltage pulse from the avalanche is typically $>1 \text{ V}$ in amplitude. These pulses are large enough that they can be counted in an ORTEC 996 Timer & Counter without amplification. Pulse inversion is, however, necessary (Fig. 2.1). In this experiment the properties of the Geiger counter will be studied, and several fundamental measurements will be made.

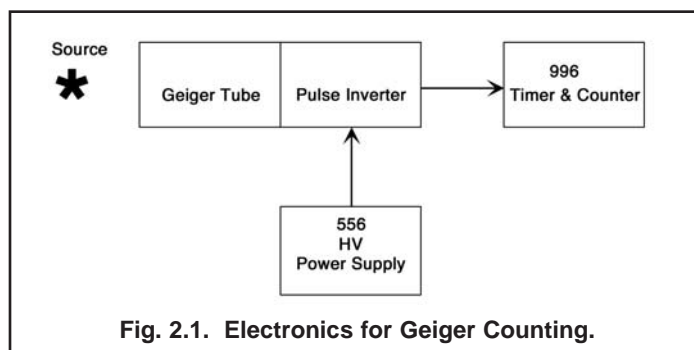

Fig. 2.1. Electronics for Geiger Counting.

EXPERIMENT 2.1

Operating Plateau for the Geiger Tube

Purpose

The purpose of this experiment is to determine the voltage plateau for the Geiger tube and to establish a reasonable operating point for the tube. Fig. 2.2 shows a counts-vs.-voltage curve for a typical Geiger tube that has an operating point in the vicinity of 1000 V.

The region between R_1 and R_2 , corresponding to operating voltages V_1 and V_2 , is called the Geiger region. Voltages $<V_2$ in Fig. 2.2 cause a continuous discharge in the tube and will definitely shorten the life of the tube.

Procedure

1. Set up the electronics as shown in Fig. 2.1.
2. Set the 996 Timer & Counter Display at X1.
3. Place the beta source ^{204}Tl from the source kit at a distance of $\sim 2 \text{ cm}$ from the window of the Geiger tube.
4. Adjust the timer of the 996 for a long period of time (~ 30 minutes).
5. Increase the (positive) high voltage on the 556 until the

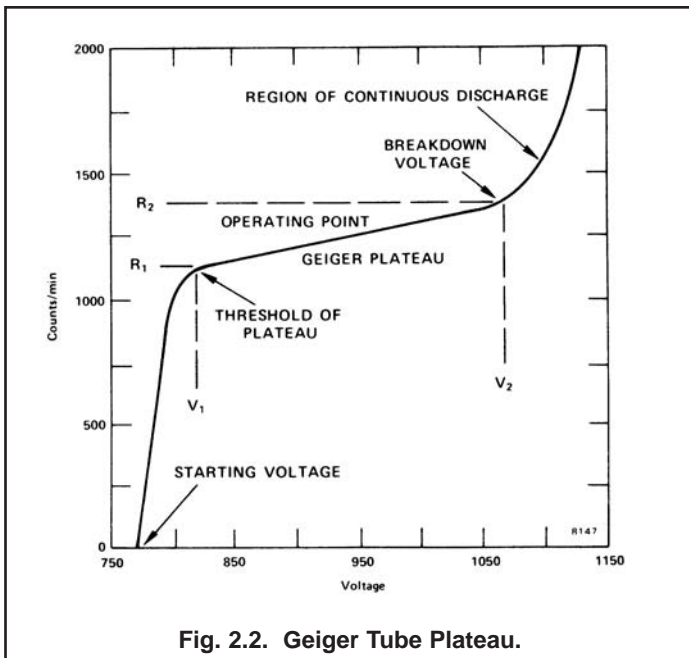

Fig. 2.2. Geiger Tube Plateau.

996 counter just begins registering counts. This point is called the starting voltage in Fig. 2.2. Starting voltages are rarely >900 V and can be as low as 250 V.

6. Reset the 996 counter, set the timer section for 1-minute time intervals, and count for 1 minute. Increase the high voltage by 50 V and count again for 1 minute.

EXERCISES

a. Continue making measurements at 50-V intervals until you have enough data to plot a curve on linear graph paper similar to that in Fig. 2.2 (caution: use only values below V_2). The region between V_1 and V_2 is usually <300 V. A sharp rise in the counting rate will be observed if you go just above V_2 . When this happens, the upper end of the plateau has been reached. Reduce the voltage to V_2 immediately. Choose the operating point for your instrument at ~50 to 70 % of the plateau range.

b. Evaluate your Geiger tube by measuring the slope of the plateau in the graph; it should be <10%. The slope of the plateau is defined as:

$$\text{slope} = \left[\frac{(R_2 - R_1)}{R_1} \right] \left[\frac{100}{V_2 - V_1} \right] \% \quad (1)$$

EXPERIMENT 2.2

Half-Life Determination

Purpose

The purpose of this experiment is to construct a decay curve and determine the half-life of an unknown isotope. The instructor will provide the unknown short half-life source to be used for this experiment. He will also tell you at what time intervals counts are to be made, and suggest a duration for the counting intervals. For example, he might tell you to take one 10-minute measurement every hour for the next 6 hours, or one 2-minute measurement every 15 minutes for the next 3 hours.

Procedure

1. Set the Geiger tube at its operating voltage.
2. Place the unknown half-life source 2 cm away from the Geiger tube window and make a count as in Experiment 2.1.
3. Record the time of day, counting duration, and number of counts.
4. After the period of time recommended by the laboratory instructor, repeat the measurement. Be sure to place the sample at exactly the same distance from the tube.
5. Continue the measurements at the time intervals recommended by the instructor. When you are not making half-life measurements, you can continue with the other parts of the experiment.

EXERCISES

- a. When you have completed your half-life measurements, correct the counting rates for dead-time losses (see Experiment 2.3), and plot the corrected counting rates as a function of time on semilog graph paper. A straight line should result.
- b. Determine the half-life from the curve and find λ , the decay constant for the isotope.

EXPERIMENT 2.3

Resolving-Time Corrections for the Geiger Counter

Purpose

Later experiments will be dealing with fast electronics (~ nanoseconds). The Geiger counter, however, is a slow device; when used for counting rates above 5000 counts/minute, it is necessary to make a dead-time correction to obtain the true counting rate. To determine this dead time, use a split source that is provided. In

counting the source, first count the right half, then both halves; finally, count the left half.

Procedure

1. Place the right half of the split source 2 cm from the window and make a 1-minute count. Record the count. Define this count to be R_1 .
2. Place the left half of the source along with the right half and make a 1-minute count. Define this count to be R_T .
3. Remove the right half and count the left half for 1 minute. Define this count to be R_2 . Calculate the resolving time of the Geiger tube with the following formula:

$$T_R = \frac{R_1 + R_2 - R_T}{2R_1 R_2} \quad (2)$$

The answer should be in min/count.

The true counting rate, R , can then be determined for an observed counting time, R_0 , from the following formula:

$$R = \frac{R_0}{1 - R_0 T_R} \text{ counts/min} \quad (3)$$

Equation (3) should be used to correct any counting rate that is above 5000 counts/minute.

EXPERIMENT 2.4

Linear Absorption Coefficient

Purpose

When gamma radiation passes through matter, it undergoes absorption primarily by Compton, photoelectric, and pair-production interactions. The intensity of the radiation is thus decreased as a function of distance in the absorbing medium. The mathematical expression for intensity, I , is given by the following:

$$I = I_0 e^{-\mu x} \quad (4)$$

where

I_0 = original intensity of the beam,

I = intensity transmission through an absorber to a distance, depth, or thickness, x ,

μ = linear absorption coefficient for the absorbing medium.

If we rearrange Eq. (4) and take the logarithm of both sides, the expression becomes

$$\ln(I/I_0) = -\mu x \quad (5)$$

The half-value layer (HVL) of the absorbing medium is defined as that thickness, $x_{1/2}$, which will cut the initial intensity in half. That is, $I/I_0 = 0.5$. If we substitute this into Eq. (5),

$$\ln(0.5) = -\mu x_{1/2} \quad (6)$$

Putting in numerical values and rearranging, Eq. (6) becomes

$$x_{1/2} = 0.693/\mu \text{ or } \mu = \frac{0.693}{x_{1/2}} \quad (7)$$

Experimentally, the usual procedure is to measure $x_{1/2}$ and then calculate μ from Eq. (7).

Procedure

1. Set the voltage of the Geiger tube at its operating value.
2. Place the ^{60}Co source about 3 cm from the window of the Geiger tube and make a 2-minute count. Record the number of counts.
3. Place a sheet of lead from the absorber kit between the source and the GM tube window and take another 2-minute count. Record the value.
4. Place a second sheet of lead on top of the first and make another count.
5. Continue adding lead sheets until the number of counts is 25% of the number recorded with no absorber.
6. Make a 2-minute background run and subtract this value from each of the above counts.

EXERCISE

Record the density-thickness of the lead in g/cm^2 and plot on semilog paper the corrected counts as a function of absorber density-thickness in g/cm^2 . The density-thickness is defined as the product of density in g/cm^3 times the thickness of the absorber in cm. Draw the best straight line through the points and determine $x_{1/2}$ and μ . How do your values compare with those indicated in ref. 8? See also Experiment 3 in this manual, in which this same experiment is done with a sodium iodide detector.

EXPERIMENT 2.5

Inverse Square Law

Purpose

There are many similarities between ordinary light rays and gamma rays. They are both considered to be electromagnetic radiation; hence they obey the classical equation

$$E = h\nu \quad (8)$$

where

E = energy of the photon in ergs,

ν = the frequency of the radiation in cycles/second,

h = Planck's constant (6.624×10^{-27} ergs • s).

Therefore, in explaining the inverse square law it is convenient to make the analogy between a light source and a gamma-ray source.

Let us assume that we have a light source that emits light photons at a rate, N_0 photons/second. It is reasonable to assume that these photons are given off in an isotropic manner, that is, equally in all directions. If we place the light source in the center of a clear plastic spherical shell, it is quite easy to measure the number of light photons per second for each cm^2 of the spherical shell. This intensity is given by

$$I_0 = \frac{N_0}{A_0} \quad (9)$$

where N_0 = the total number of photons/second from the source, and A_0 = the total area of the sphere in cm^2 .

Since $A_0 = 4\pi R_0^2$, where R_0 is the radius of the sphere, Eq. (9) can then be written

$$I_0 = \frac{N_0}{4\pi R_0^2} \quad (10)$$

Since N_0 and 4π are constants, I_0 is seen to vary as $1/R_0^2$. The purpose of this experiment is to verify Eq. (10).

Procedure

1. Set the GM tube at the proper operating voltage, and place the ^{60}Co source 1 cm away from the face of the window.
2. Count for a period of time long enough to get reasonable statistics (~4000 counts).
3. Move the source to 2 cm and repeat the measurement for the same amount of time. Continue for the distances listed in Table 2.1. (Note that for the longer distances the time will have to be increased to obtain the same statistics).

Table 2.1

Distance	Activity (counts/min)	Corrected Activity (counts/min)
1 cm		
2 cm		
3 cm		
4 cm		
5 cm		
6 cm		
7 cm		
8 cm		

EXERCISES

a. Correct the activity for dead time and background and fill in the corrected activity in Table 2.1. On linear graph paper, plot the corrected activity (x axis) as a function of distance. Since the intensity is proportional to the activity, this plot should have the $1/R_0^2$ characteristics exhibited by Eq. (10). From the corrected activities in Table 2.1,

$$A = \frac{K}{R^2} \quad (11)$$

where

R = the distance for the measurement (cm),

A = the correct activity, and

K = a constant which is to be determined from the individual entries in Table 2.1.

b. Find K for each entry in Table 2.1. Calculate an average K (\bar{K}) from the eight values. What is the percent deviation of each individual K value from \bar{K} ?

EXPERIMENT 2.6 Counting Statistics

Purpose

As is well known, each measurement made for a radioactive sample is independent of all previous measurements, because radioactive decay is a random process. However, for a large number of individual measurements, the deviation of the individual count rates from what might be termed the "average count rate" behaves in a predictable manner. Small deviations from the average are much more likely than large deviations. In this experiment we will see that the frequency of occurrence of a particular deviation from this average, within a given size interval, can be determined with a certain degree of confidence. Fifty independent measurements will be made, and some rather simple statistical treatments of the data will be performed.

The average count rate for N independent measurements is given by

$$\bar{R} = \frac{R_1 + R_2 + R_3 + \dots + R_N}{N} \quad (12)$$

where R_1 = the count rate for the first measurement, etc., and N = the number of measurements.

In summation, the notation \bar{R} would take the form

$$\bar{R} = \frac{\sum_{i=1}^N R_i}{N} \quad (13)$$

The deviation of an individual count from the mean is $(R - \bar{R})$. From the definition of \bar{R} it is clear that

$$\sum_{i=1}^N (R_i - \bar{R}) = 0 \quad (14)$$

The standard deviation $\sigma = \sqrt{\bar{R}}$.

Procedure

1. Set the operating voltage of the Geiger tube at its proper value.
2. Place the ^{60}Co source far enough away from the window of the GM tube so that ~ 1000 counts can be obtained in a time period of 0.5 min.
3. Without moving the source, take 50 independent 0.5 minute runs and record the values in Table 2.2. (Note that you will have to extend Table 2.2; we have shown only ten entries).

The counter values, R , may be recorded directly in the table since, for this experiment, R is defined as the number of counts recorded for a 0.5 minute time interval.

4. With a calculator determine \bar{R} from Eq. (12). Fill in the values of $R - \bar{R}$ in Table 2.2. It should be noted that these values can be either positive or negative. You should indicate the sign in the data entered in the table.

Run	R	σ	$R - \bar{R}$	$(R - \bar{R})/\sigma$		$(R - \bar{R})/\sigma$ (Rnd'd Off)	
				Typical	Measured	Typical	Measured
1				-0.15		0	
2				+1.06		+1.0	
3				+0.07		0	
4				-1.61		-1.5	
5				-1.21		-1.0	
6				+1.70		+1.5	
7				-0.03		0	
8				-1.17		-1.0	
9				-1.67		-1.5	
10				+0.19		0	

*Typical values of $(R - \bar{R})/\sigma$ and $(R - \bar{R})/\sigma$ rounded off; listed for illustrative purposes only.

EXERCISES

- a. Calculate σ , and fill in the values for σ and $(R - \bar{R})/\sigma$ in the table, using only two decimal places. Round off the values for $(R - \bar{R})/\sigma$ to the nearest 0.5 and record the values in the table. Note that in Table 2.2 we have shown some typical values of $(R - \bar{R})/\sigma$ and the rounded-off values.
- b. Make a plot of the frequency of the rounded-off events $(R - \bar{R})/\sigma$ vs. the rounded-off values. Fig. 2.3 shows this plot for an ideal case. Note that at zero there are eight events, etc. This means that in our complete rounded-off data in Table 2.2 there were eight zeros. Likewise, there were seven values of +0.5, etc. Does your plot follow a normal distribution similar to that in Fig. 2.3?

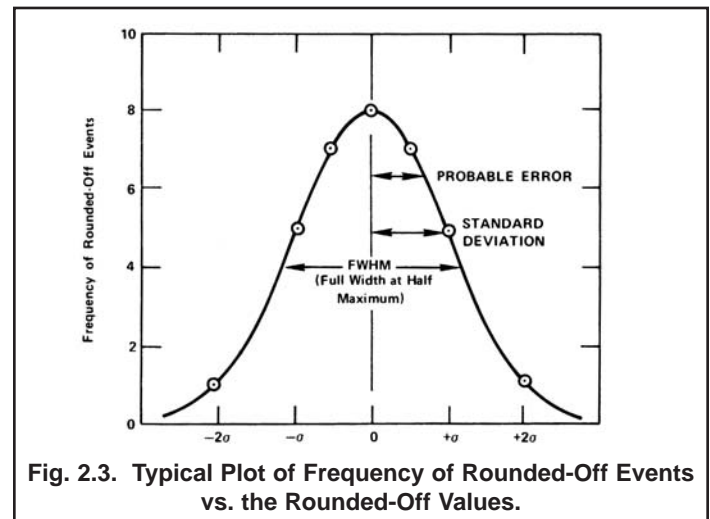

Fig. 2.3. Typical Plot of Frequency of Rounded-Off Events vs. the Rounded-Off Values.

References

1. G. F. Knoll, Radiation Detection and Measurement, John Wiley and Sons, New York (1979).
2. E. W. Emery, Geiger-Mueller and Proportional Counters in Radiation Dosimetry, II, F. H. Attix and W. C. Roesch, Eds., Academic Press, New York, (1966).
3. A. Peeva and T. Karatoteva, Nucl. Instrum. Methods 118, 49 (1974).
4. H. L. Andrews, Radiation Biophysics, Prentice-Hall, New Jersey (1974).
5. V. Arena, Ionizing Radiation and Life, The C. V. Mosby Co. Missouri (1971).
6. G.D. Chase and J. L. Rabinowitz, Principles of Radioisotope Methodology, 3rd Edition, Burgess Publishing Co., Minnesota (1967).
7. C. M. Lederer and V. S. Shirley, Eds., Table of Isotopes, 7th Edition, John Wiley and Sons, Inc. New York (1978).
8. Radiological Health Handbook, U.S. Dept. Of Health, Education, and Welfare, PHS Publication 2016. Available from National Technical Information Service, U.S. Dept. Of Commerce, Springfield, Virginia.